

Synergy in technics.

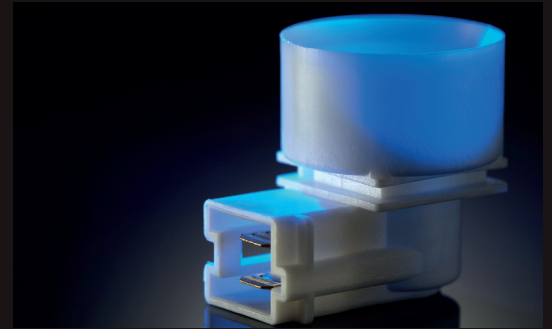

## Lamp holders

In the fast-growing industry of refrigerators, freezers, microwave ovens, stoves ... reliable and safe lamp holders are required.

We are able to offer the development and production of lamp holders according to your wishes and applicability demands including mercury free material (for food storage equipment) and direct mounting onto housings without screws.

Top quality products are guaranteed with the most up-to-date technological procedures and equipment.

## LAMP HOLDERS LHE 14/L WITH SPHERE SWITCH

### Features:

- The mechanism of the switch/lamp holder does not contain mercury and may be safely used in food storage equipment
- When fitted to the lid of a freezer storage cabinet, the switch will operate the lamp when the lid is opened to the angle of tilt shown in drawing
- Miniature design
- VDE approved
- Patent registered no. 202 03 000.8., 200100051

### Applications:

- Household applications (chest freezers)

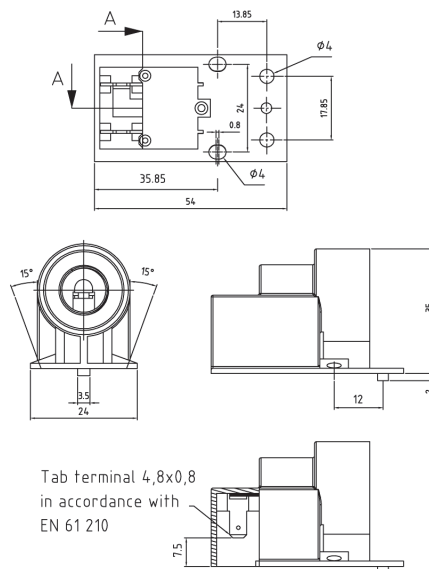
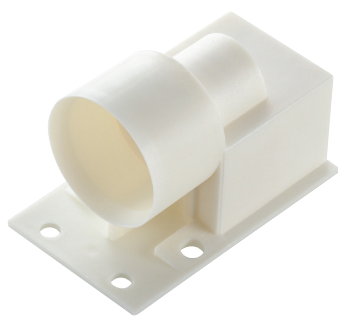

D (right)  
L (left)  
LHE14/L

BUILT IN POSITION OF LAMPHOLDER AND TURN ON - OFF ANGLES LEFT (LHE14/L)

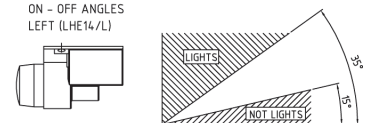

BUILT IN POSITION OF LAMPHOLDER AND TURN ON - OFF ANGLES RIGHT (LHE14/D)

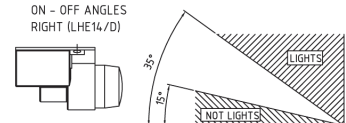

### LAMP HOLDER E14/90 RAST 5 mm

#### Features:

- Miniature design
- RAST 5mm connection system for LUMBERG type 3614 02 K01 or equivalent
- Direct mounting onto housing of appliance without additional screws
- Explosion proof version for appliances with refrigerant R600; upon request available with rubber sealing
- Patent pending

#### Applications:

- Household applications (refrigerators, freezers, cooker, hoods)

### LAMP HOLDER E14 OE18

#### Features:

- Miniature design
- Direct mounting onto housing of appliance without additional screws

#### Applications:

- Household applications (refrigerators, freezers, cooker, hoods)

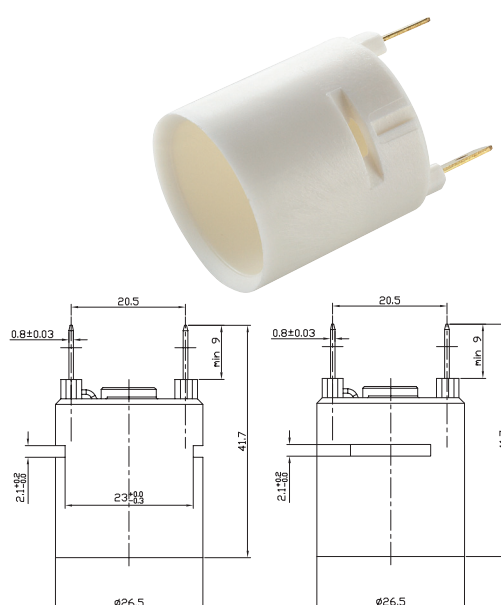

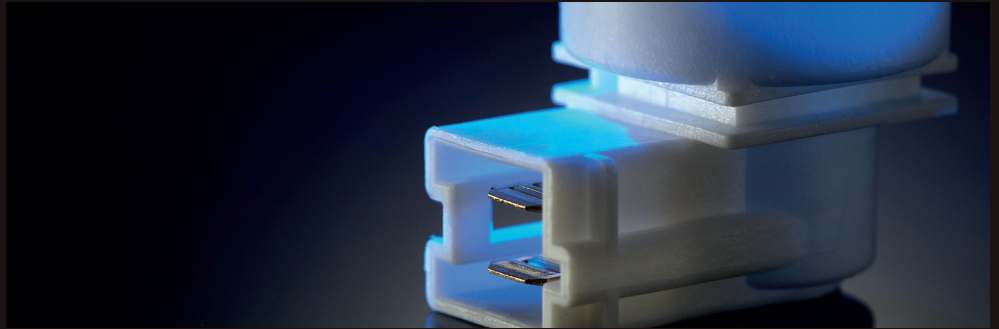

STRIP'S d.o.o. • Kandrše 7 • 1252 Vače • Slovenia • Europe

**T** +386 (0)3 567 07 70 • **F** +386 (0)3 567 07 80

**E** info@strips.eu • **W** www.strips.eu



Quality, as one of the most important elements, is manifested as great attention to quality assurance, as well as investment in quality management system. We are certified by ISO 9001:2008 and ISO 14001:2004.